

HOW TO INSTALL LZ ZOOM GELS

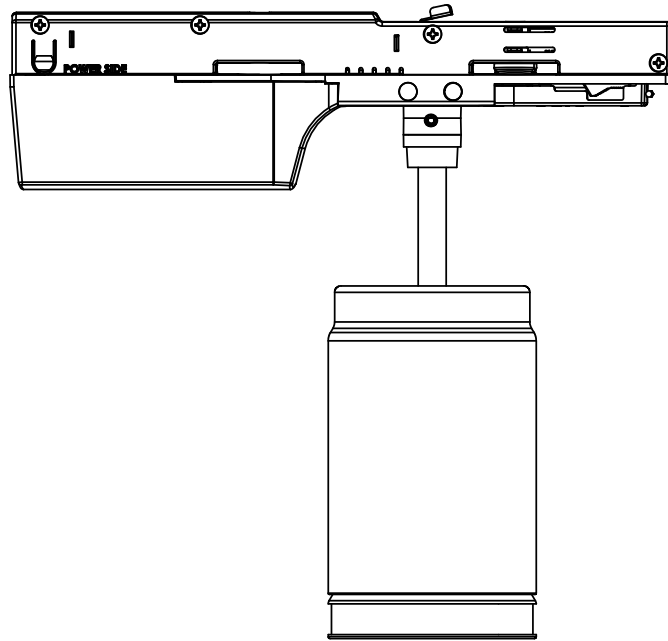

TO PREVENT RISK OF SHOCK, TURN OFF ELECTRICITY PRIOR TO INSTALLATION OR MAINTENANCE

IMPORTANT SAFETY INFORMATION

WHEN INSTALLING OR USING THIS LIGHT FIXTURE, BASIC SAFETY PRECAUTIONS SHOULD ALWAYS BE FOLLOWED, INCLUDING THE FOLLOWING:

- READ ALL INSTRUCTIONS.
- DO NOT INSTALL IN DAMP OR WET LOCATIONS.
- DO NOT INSTALL ANY FIXTURE ASSEMBLY CLOSER THAN SIX INCHES FROM ANY CURTAIN OR SIMILAR COMBUSTIBLE MATERIAL.
- RECOMMENDED TO BE PERFORMED BY A QUALIFIED ELECTRICIAN.
- THIS PRODUCT MUST BE INSTALLED IN ACCORDANCE WITH NATIONAL ELECTRICAL CODES AND ALL OTHER LOCAL CODES BY A PERSON FAMILIAR WITH THE CONSTRUCTION AND OPERATION OF THE PRODUCT AND THE HAZARDS INVOLVED.
- TURN OFF POWER PRIOR TO INSTALLATION OR MAINTENANCE.

SAVE THESE INSTRUCTIONS

CONFIDENTIAL-PROPRIETARY INFORMATION - THE INFORMATION HEREIN IS PROTECTED UNDER COPYRIGHT AND IS OF A PROPRIETARY NATURE AND IS SUBMITTED IN CONFIDENCE FOR USE BY OUR CLIENTS ONLY. UNAUTHORIZED REPRODUCTION, PUBLICATION, DISTRIBUTION OR DISSEMINATION IN WHOLE OR PART, IS EXPRESSLY PROHIBITED. THE INFORMATION CONTAINED HEREIN IS AND REMAINS THE PROPERTY OF LIGHTING SERVICES INC. AND RECEIPT OR POSSESSION OF THIS INFORMATION CONFERS NO RIGHT IN OR LICENSE TO DISCLOSE TO OTHERS THE SUBJECT MATTER CONTAINED HEREIN FOR ANY BUT AUTHORIZED PURPOSES. COPYRIGHT LIGHTING SERVICES INC. ALL RIGHTS RESERVED



LIGHTING SERVICES INC 2 HOLT DRIVE STONY POINT, NY 10980-1996 TEL: 845-942-2800 www.LightingServicesInc.com

HOW TO INSTALL LZ ZOOM GELS



- NOTES:**
1. SHUT OFF THE POWER TO THE FIXTURE.
 2. IT IS RECOMMENDED TO REMOVE THE FIXTURE FROM ITS MOUNTING FOR EASIER ACCESS.
 3. PULL ACCESSORY CARTRIDGE ALONG WITH GEL HOLDERS AWAY FROM THE FIXTURE.
 4. OPEN THE GEL HOLDER, LIKE A CLAMSHELL. THE GEL HOLDER IS HELD CLOSED WITH INTERNAL MAGNETS.
 5. INSERT GEL AND CLOSE GEL HOLDER.
 6. REINSERT THE GEL HOLDERS AND ACCESSORY CARTRIDGE.

