

# LP1 • 120/277V • LED • COB

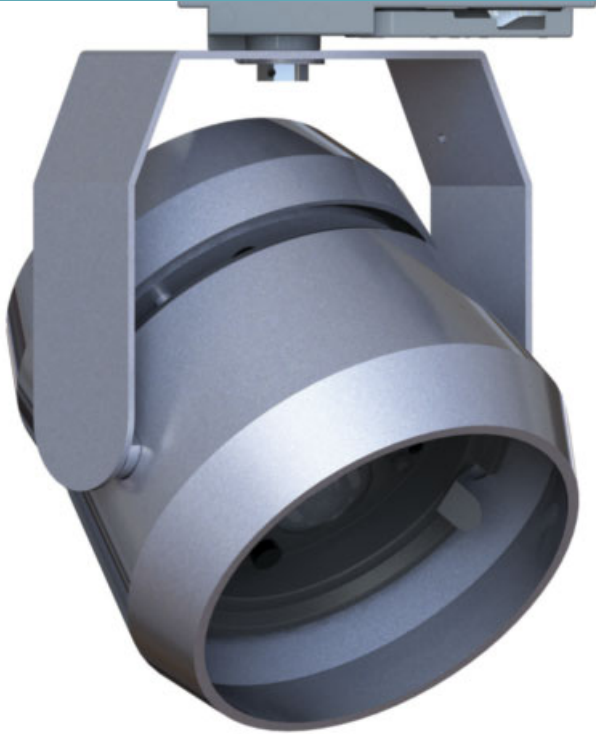

**This versatile spotlight creates a high intensity shaft of light that is perfect for long-throw applications.**

- 4° optic produces 97,000 CBCP with 1090 lumens at 17 watts
- System efficiency up to 43 lumens/watt
- Exceeds ANSI specifications by maintaining extremely tight color consistency over the life of the fixture
- Tested to LM79 and LM80 Protocols
- 50,000 hour life to 70% lumen output, L<sub>70</sub> at 95°F max ambient
- Hidden integral electronic driver, compatible with various dimmers down to 0.1%
- Choice of beam spread (fixed optics)
- Color Rendering Index (CRI) 90+
- Color consistency, 2 MacAdam ellipses
- No UV or IR emissions; no mercury or lead
- On/off safety switch (on most mounting types)
- Field replaceable, connector-less LED module
- Sturdy aluminum housing
- Self locking vertical and horizontal focusing
- Internal multiple accessory clips accept B size LSI gels and accessories
- Finishes: LSI Black, White, and Silver
- Fixture weight: 3 lbs

## FIXTURE PART NUMBERS

Please review the **ORDERING INFORMATION** section on the next page as well as the **MOUNTING OPTIONS** on page 3 to create a part number for each fixture that specifies the following:

- LED Module
- LED Rating
- Color Temperature
- Optic (mm/beam spread)
- Fitting/Controls (Dimming)
- Voltage
- Finish

### PART NUMBER

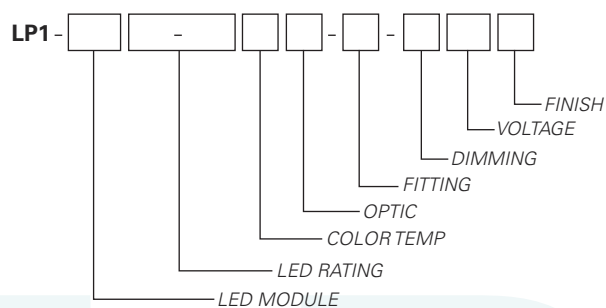

Example Part Number: **LP1-ZE410-903004-00-TE120W** is a fixture with a 4 LED Array module, 1090 Lumen/90 CRI/17 Watt LED rating, 3000°K Color Temperature, 35mm 4° Optic, 00Track fitting with Trailing Edge group dimming capability, 120V and a White finish.

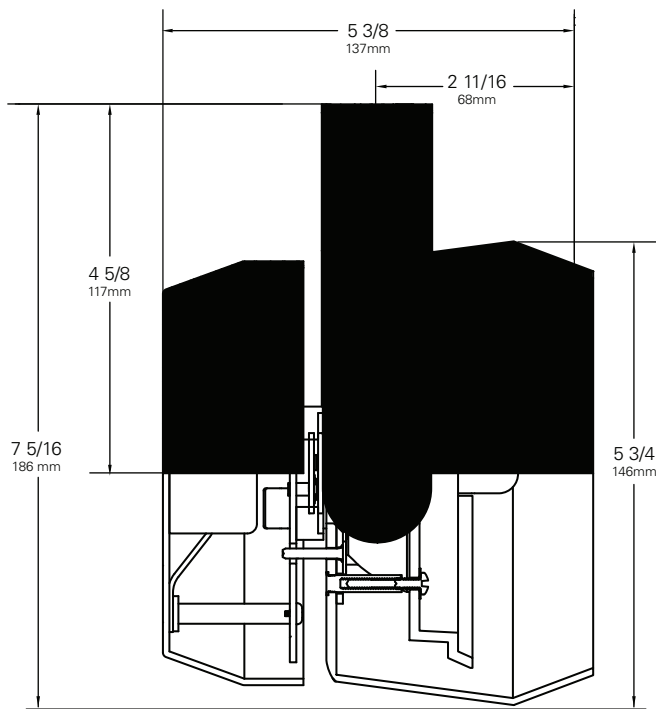
**LP1** • 120/277V • LED • COB**DRIVER TYPE (Electronic)**

Input Power (A) - 120V	0.13
Input Power (A) - 277V	0.05
Wattage	17
Power Factor - 115V	0.95

**Chromaticity Specifications**

LED	R <sub>a</sub> -CRI	R <sub>f</sub> -Fidelity	R <sub>g</sub> -Gamut Area
ZE4	90	92	102

**ORDERING INFORMATION****Base Fixture Model**

LP1-ZE4 = 2x2 Array

**LED Rating (Lumens/CRI/Wattage)**

10-90 = 1090/90/17

**Color Temperature**

27 = 2700K     30 = 3000K

35 = 3500K     40 = 4000K

**Optic**

04 = 35mm/ 4°     12 = 35mm/ 12°     25 = 35mm/ 25°

**Fitting/Controls (Dimming)**

00-TE = Track Fitting & Trailing Edge (5%)

00-LE = Track Fitting & Leading Edge (5% - 120V only)

0D-ED = Track Fitting with Integral Dimmer (0.1%)

00EF-TE = Security/Worklight Track Fitting  
& Trailing Edge (5%)

2G-TE = Universal Fitting & Trailing Edge (5%)

2G-LE = Universal Fitting & Leading Edge (5% - 120V only)

2G-DX = Universal Fitting & DMX (<1%)

3G-TE = Pipe Clamp Fitting & Trailing Edge (5%)

3G-LE = Pipe Clamp Fitting & Leading Edge (5% - 120V only)

3G-DX = Pipe Clamp Fitting & DMX (<1%)

5A-TE = Canopy Fitting & Trailing Edge (5%)

5A-LE = Canopy Fitting & Leading Edge (5% - 120V only)

5A-DX = Canopy Fitting & DMX (<1%)

5B-10 = Canopy Fitting & 0-10V (0.1%)

5B-ED = Canopy Fitting with Integral Dimmer (0.1%)

- Coiled Cord is available only with **2G** and **3G** mounting options. Change 2G to **2C** and 3G to **3C**. (When a coiled cord is not specified, a straight cord is provided.)

**Voltage**

120 = 120V     230 = 220-240V     277 = 277V

**Finish**

B = Black     W = White     S = Silver

**LP1-ZE4**

FITTURE MODEL

**10-90**

LED RATING

**30**

COLOR TEMP

**04 - 00-TE**

OPTIC FITTING/DIMMING

**120**

VOLTAGE

**W**

FINISH

**Other Options (Consult Factory):**

- Custom Stems, specify length (4" - 48")
- Custom Finish, RAL palette

# LP1 • MOUNTING OPTIONS

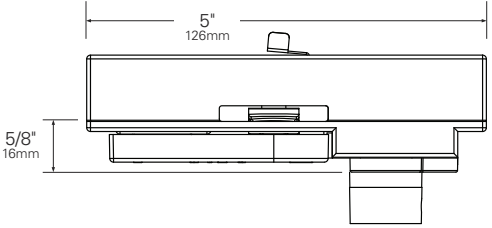
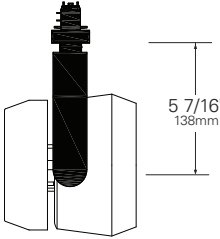
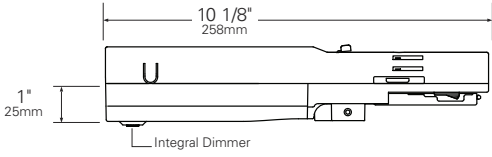
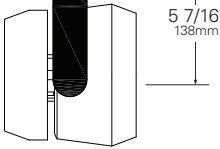
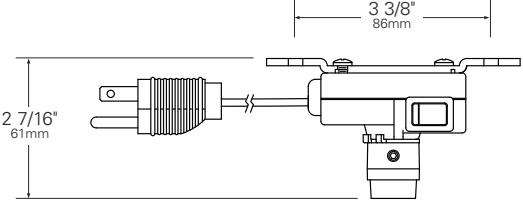
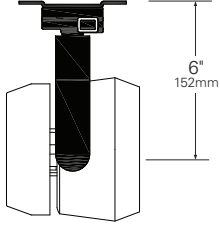
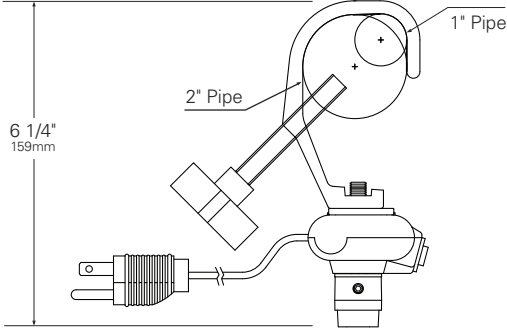
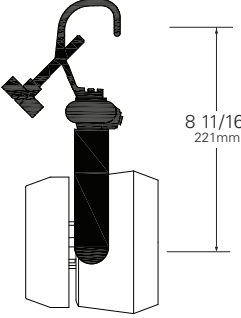
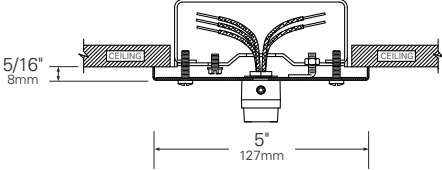
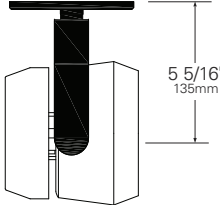
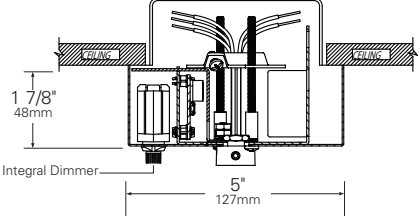
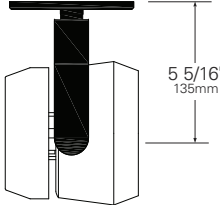
FITTING	SIDE VIEW	PROFILE VIEW
<p><b>00 Track Fitting/ 00EF Security/Worklight Fitting</b></p>		
<p><b>0D-ED Track Fitting with Integral Dimmer</b></p>		
<p><b>2G Universal Fitting</b></p>		
<p><b>3G Pipe Clamp Fitting</b></p>		
<p><b>5A Canopy Fitting with TE, LE and DX Dimming</b></p>		
<p><b>5B Canopy Fitting with Integral Dimmer and 0-10V Dimming</b></p>		

# LP1 • PERFORMANCE

The performance characteristics of the LP SuperSPOT family of products can be customized based on the LED module and the optic selected.

Each available LED module is defined by four characteristics – the color rendering index (CRI), the correlated color temperature (CCT), the power that it uses (watts), its “available lumens” and beam spread. Note that available lumens is a theoretical value that represents the light output of the module on its own – no fixture or optic attached.

In the LSI part number, the LED module is specified with a letter and a number that immediately follow the product series number. For example, in the part number LP1-ZE410-903004-00-TE120B, the “ZE410-903004” represents an LED module with an output of 1090 lumens, a CRI of 90, a power usage of 17 watts, color temperature of 3000K and a 4-Degree beam.

Additional parameters, such as Center Beam Candle Power (CBCP), Delivered Lumens, and Efficiency (Lumens per Watt) are all shown in a table that is organized by LED module and optic combination.

CBCP = Center Beam Candle Power			
LED Module	Optic (Reflector)		
Lumens/CRI/Wattage	04°	12°	25°
1090/90/17	97,776	14,989	3,981

Delivered Lumens			
LED Module	Optic (Reflector)		
Lumens/CRI/Wattage	04°	12°	25°
1090/90/17	524	727	658

Efficiency = Lumens Per Watt			
LED Module	Optic (Reflector)		
Lumens/CRI/Wattage	04°	12°	25°
1090/90/17	31	43	39

LED Module Lumens/CRI/Wattage SKU Code	1090/90/17
Nominal Fixture Power (+/- 20%), Watts	17
Maximum Inrush Current Amps	10
Minimum Power Factor	0.92

*Inrush current is instantaneous current drawn by the LED only when fixture is initially powered on or instantaneously changed from full dim to full bright. For more details see Dimming Application Sheet, IS-0119.*

# LP1 • PHOTOMETRIC DATA

## PHOTOMETRIC DATA

### LP1 Series

Beam Spread (minimum) **4°**  
 Center Beam Candlepower **97,776**  
 CRI **90+**

### LP1 Series

Beam Spread (minimum) **12°**  
 Center Beam Candlepower **14,989**  
 CRI **90+**

### LP1 Series

Beam Spread (minimum) **25°**  
 Center Beam Candlepower **3,981**  
 CRI **90+**

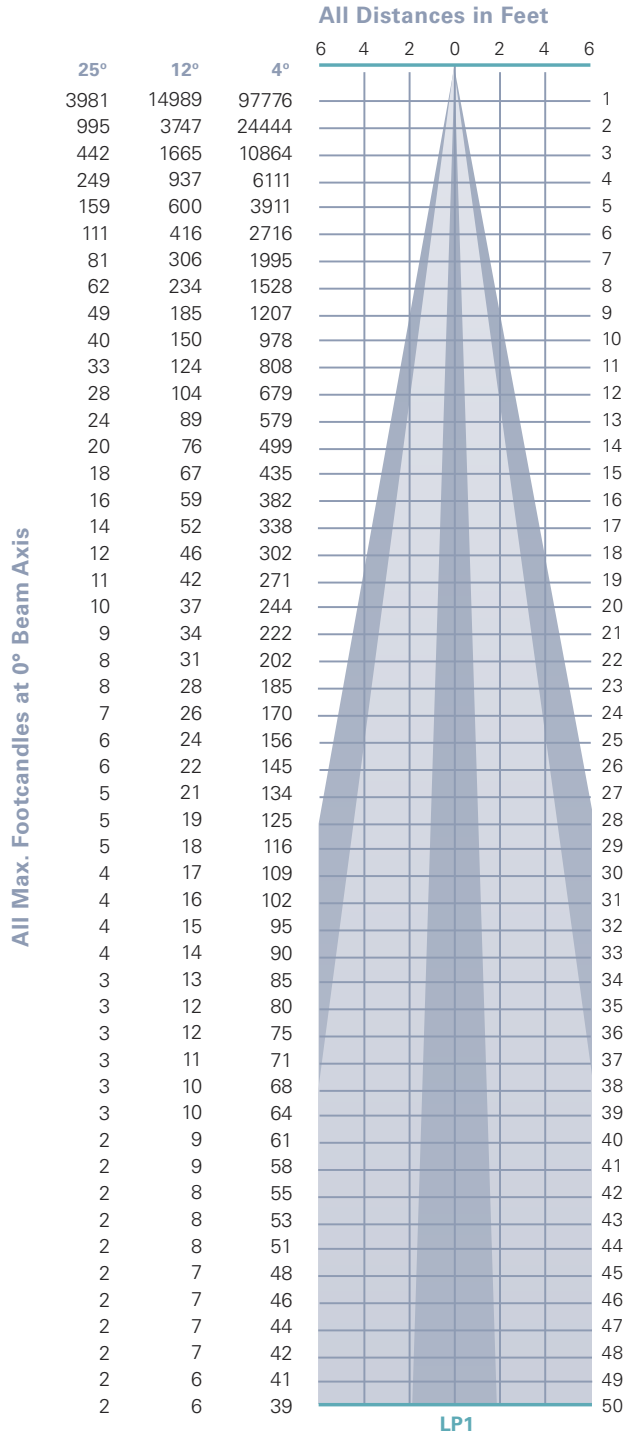

# LP1 • ACCESSORIES



## LOUVER HEX BB

1/8" thick Hexcell black metal louver used for thin profile. Black finish.

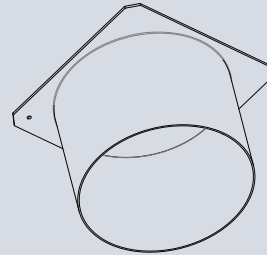

## HOOD LP1B\*

6 inch deep hood. Interior flocking included to control spill light and glare. Black finish.

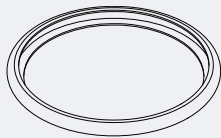

## BACKER RING BB

Stainless steel ring to hold gel when no other size B accessory is being used. Black finish.

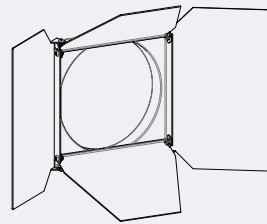

## BARNDOOR LP1B\*

4-way individually adjustable blades for control of light beam. Black finish.

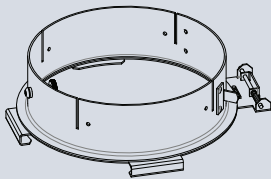

## LP1 HOLDER

External Accessory cartridge to hold LP1 hood and LP1 barndoor. Black finish.

\*LP1 Holder (External Accessory Cartridge) required

# LP1 • GELS

As the foremost innovator in accent lighting, LSI offers a complete range of pre-cut Gels to modify the spread and color of light.



## SPREAD GELS

Size: B (108 mm diameter)	Spread Gel
GEL-L1-B	1° Spread Gel
GEL-L5-B	5° Spread Gel
GEL-L10-B	10° Spread Gel
GEL-L20-B	20° Spread Gel
GEL-L30-B	30° Spread Gel
GEL-L40-B	40° Spread Gel
GEL-L60-B	60° Spread Gel
GEL-L80-B	80° Spread Gel
GEL-L30X5-B	30° by 5° Spread Gel
GEL-L40X1-B	40° by 1° Spread Gel
GEL-L60X1-B	60° by 1° Spread Gel
GEL-L60X10-B	60° by 10° Spread Gel
GEL-L75X45-B	75° by 45° Spread Gel
GEL-L90X60-B	90° by 60° Spread Gel
GEL-R101-B	Beam Softener

## COLOR GELS

Size: B (108 mm diameter)	Gel Color	% of Light Transmission	Size: B (108 mm diameter)	Gel Color	% of Light Transmission
GEL-R2-B	Bastard Amber	78	GEL-R312-B	Canary	85
GEL-R7-B	Pale Yellow	96	GEL-R331-B	Shell Pink	68
GEL-R12-B	Straw	88	GEL-R383-B	Sapphire Blue	4
GEL-R13-B	Straw Tint	78	GEL-R397-B	Pale Grey	70
GEL-R14-B	Medium Straw	68	GEL-R2001-B	Storaro Red	12
GEL-R21-B	Golden Amber	43	GEL-R2004-B	Storaro Green	15
GEL-R25-B	Orange Red	14	GEL-R2009-B	Storaro Violet	3
GEL-R26-B	Light Red	12	GEL-R3202-B	Full Blue	36
GEL-R27-B	Medium Red	4	GEL-R3204-B	Half Blue	52
GEL-R57-B	Lavender	24	GEL-R3206-B	Third Blue	64
GEL-R62-B	Booster Blue	54	GEL-R3216-B	Eighth Blue (Boosts 3200K to 3300K)	81
GEL-R71-B	Sea Blue	30	GEL-R3318-B	Tough 1/8 Minusgreen	89
GEL-R72-B	Azure Blue	44	GEL-R3410-B	Roscoun (1/8 CTO) (Reduces 5500K to 4900K)	92
GEL-R91-B	Primary Green	7	GEL-R3441-B	Full Straw (CTS)	50
GEL-R97-B	Light Grey	50	GEL-R3443-B	Quarter Straw (CTS)	81
GEL-R98-B	Medium Grey	25	GEL-R4330-B	CalColor 30 Cyan	63
GEL-R101-B	Light Frost	N/A	GEL-R4415-B	CalColor 15 Green	67
GEL-R104-B	Tough Silk	N/A	GEL-R4490-B	CalColor 90 Green	25
GEL-R119-B	Lt. Hamburg Frost	N/A	GEL-R4860-B	CalColor 60 Pink	46
GEL-R121-B	Blue Diffusion	N/A	GEL-R4890-B	CalColor 90 Pink	38
GEL-R305-B	Rose Gold	75	GEL-R4930-B	CalColor 30 Lavender	47

\* Backer Ring B required to hold gels when no other rimmed "B" accessories are used.

Type	ROSCO #	ROSCO Description	Resulting CCT
Amber Filters Lower CCT	3420	Double CTO	1531
	3407	Sun CTO	1999
	3401	Sun 85	2154
	3411	Sun 3/4 CTO	2154
	3408	Sun 1/2 CTO	2414
	3409	Sun 1/4 CTO	2664
	3410	Sun 1/8 CTO	2830
	3114	UV Filter	2930
Blue Filters Raise CCT	3220	Double Blue	N/A
	3202	Full Blue	4942
	3203	Three-Quarter Blue	4286
	3204	Half Blue	3769
	3206	Third Blue	3517
	3208	Quarter Blue	3297
	3216	Eighth Blue	3112